

Maintenance

Wipe the product with a soft, damp cloth only. Do not use abrasives, alcohol or solvent based cleaners.

Glass Table Top (04-01-01)

A glass table top is available as an accessory.

TROUBLESHOOTING

1) THE UNIT DOES NOT WORK

When the battery is empty

Solution: The product turns off automatically when the battery is empty due to continuous use. It will turn itself back on when the battery has been charged to a minimum level. This can take approx. 1-3 hours to reach the minimum operating voltage. Charge the product until the LED is lit green.

When one or both fuses are defect

Solution: Check fuses and replace if necessary. Make sure that the charger is plugged into the product before plugging into the mains (otherwise the fuse may blow). Keep product away from moisture.

When the red light on the charger is not lit

Solution: Check the power supply, if the light on the charger is still not lit, the charger is faulty.

When the charge is interrupted

Solution: Make sure the charger is correctly plugged into the socket of the unit!

When the charge is to short

Solution: Charge the product until the LED is lit green.

2) THE REMOTE CONTROLLER DOES NOT WORK

a) The battery is empty or the batteries are inserted the wrong way round.

b) Point the remote controller at the unit from different angles.

c) Switch the LED product off or pull the plug to reset it.

If your product does not function any longer, then please first examine if there is a problem with the power supply or if you have handled the product incorrectly. If your product is defect in any way, please contact the vendor.

Upgrade IR to RC

As standard Moree LED Pro products are equipped with infrared technology (IR). The upgrade from infrared to radio equipment (RC) allows you to control many LED products, using a RC remote control or computer dongle, at the same time, at a great distance. So one can, for example, illuminate large halls by pressing a button in a particular colour. In addition, the upgrade includes 20 colours and 12 programs.

Original Packaging

The device can be safely transported in the original packaging. If insufficient protective packaging is used, the customer is liable for any damages during transportation.

PLEASE KEEP THE ORIGINAL PACKAGING AND USE IT, IF POSSIBLE, IN CASE OF WARRANTY OR RETURN OF THE EQUIPMENT.

Disposal/ Ecology

Packaging material and appliance are made from recyclable materials. Separation of the remaining waste materials into different types facilitates the recycling of valuable raw materials. When the appliance is to be no longer used please dispose of the appliance in the proper manner.



This Symbol on the product indicates that it should not be disposed in the normal household waste. Please take it to a recycling point for electrical and electronic appliances to be recycled in a proper manner.

Rechargeable batteries which are dead or defective should not be disposed of in the household rubbish; always take them to a special waste disposal and make an important contribution to protecting our environment.

Please obtain information on disposal from your local authority.

Distribution

www.moree.de

Moree Ltd.
Kaiserswerther Markt 11
40489 Düsseldorf
Germany

Designed and produced by Moree in Germany © 2011
Design Patented. Products are subject to change.

LOUNGE 45/55/75/105 LED PRO ACCU

Instruction Manual - IR Version

Mod. Lounge LED Pro Accu 45 (07-09-04), 55 (07-09-01), 75 (07-09-02), 105 (07-09-03)

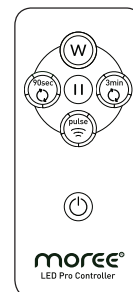

- Inclusive Remote Control and Charger



- Please read the instruction manual fully, before using the product. Keep the manual for the entire life of the product.
- Make sure to charge the product fully before the first use and every 2 months when stored for a long period of time.



GB Instruction Manual

Dear customer,
We are delighted that you have chosen a Moree product.

SAFETY PRECAUTIONS LED PRODUCT

- Before using the product, please read the safety precautions fully. Keep the manual for the entire life of the product.
- **IMPORTANT: THE PRODUCT MAY ONLY BE CHARGED IN DRY ROOMS. THERE MUST BE NO MOISTURE ON THE CHARGING POINT OR ON THE CHARGER.**
- The product may only be used when positioned horizontally, with the top facing upwards on firm, non-flammable ground and should not be covered.
- The product may only be charged with the supplied charger.
- Make sure your voltage corresponds to the voltage printed on the product.
- Stop operating the product immediately if it emits smoke, a strange smell, or otherwise behaves abnormally.
- The product may only be used after correct installation. Disconnect the product from the mains supply before opening.
- Do not allow dirt or metal objects (such as keys) to contact the charging point.
- Avoid dropping or subjecting the product to severe impact.
- Max. load is 5 kg.
- Do not pull on any cables !
- Do not alter the product in any way. Faulty or unqualified repair work may cause injury to the user.
- If the appliance (including cord and charger) shows any defect, stop using it and only replace damaged components with specific ones that are available from the manufacturer or a representative.

• **CAUTION! WHEN DISASSEMBLING DO NOT LOOK DIRECTLY INTO THE OPERATING LIGHT SOURCE - RISK OF IRREVERSIBLE EYE DAMAGE!**

Specifications LED Product

Due to the production process the surfaces of the tabletop could be slightly convex.

Dimensions:	Ø approx. 84 cm, H 45, 55, 75, 105 cm
Material/ colour:	ABS, gloss finished, white translucent, UV resistant, Aluminium brushed, anodized approx. 24,5/26,0/26,5/33,0 kg
Weight:	Multicolour LEDs, max 13W
Illuminant:	12V, 12Ah
Battery:	approx. 16h/ IR, 20h/ RC
Operating time	III
Protection class:	IP 20, for indoor use
Protection grade:	
Charger:	110-240 V~, 50-60 Hz, Vout 12V, 3A

Moree product appliances meet European safety standards.



Construction Diagram

REMOVE PROTECTIVE PLASTIC FILM!

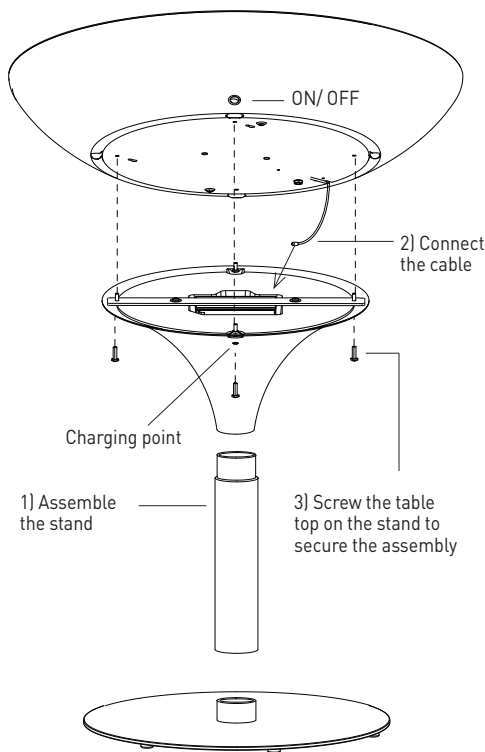

TRANSPORTATION BAR

Please secure the bar before transportation !
Before assembly of the product, unscrew the bar at both ends !

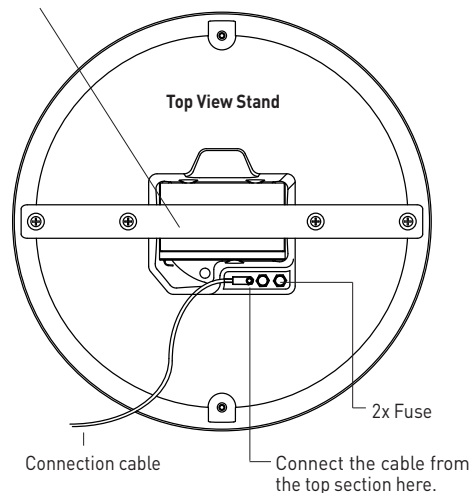

Remote Control

[1] Single Press [2] Double Press

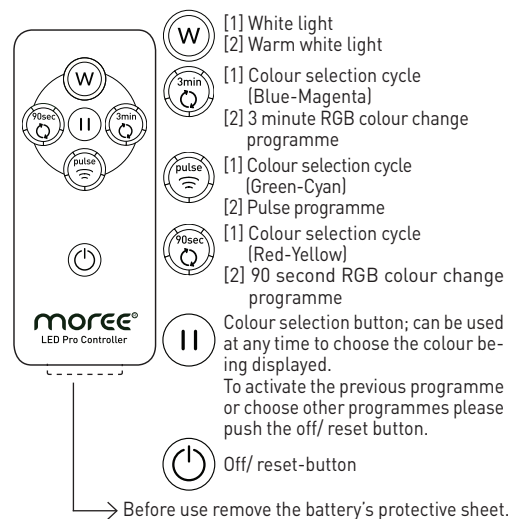

Note: Colours printed on the remote may differ from those displayed by the LED unit.

SAFETY PRECAUTIONS - BATTERY

- THE PRODUCT MAY ONLY BE CHARGED WITH THE SUPPLIED CHARGER.
- THE BATTERY MUST ONLY BE CHANGED BY QUALIFIED PERSONNEL USING THE SAME BATTERY TYPE !
- DO NOT ATTEMPT TO DISASSEMBLE, ALTER OR APPLY HEAT TO THE BATTERY !
- In case of leakage, do not allow liquid to come into contact with skin. If liquid is spilt on clothes or skin immediately wash off with water. Should problems occur, contact a doctor.

Charging the battery

- To charge the battery, first plug the charger into the charging point and then connect the charging plug to the power supply.
- Before use charge the battery fully.
- The product will automatically shut off when the battery is empty. It will turn on again when the battery is recharged - this may take up to 3 hours.

In order to maintain a longer battery life, please comply with the following instructions when using this product:

- If the product is not used for a long period of time please turn it off (via the switch on the product), because the standby mode will slowly empty the battery.
- When the product is stored under 25°C it can be left for up to 2 months. If left for longer than this period, make sure to charge it fully again.
- If the battery is quickly depleted even after charging, it has reached the end of its life span. Purchase a new battery.

• Please replace the battery after the correct time interval shown below, and do not continue to use the battery after its recommended replacement time.

Temperature of battery	Replacement time
Below 25°C (77°F)	6 Years
30°C (86°F)	4 Years
40°C (104°F)	2 Years

SAFETY PRECAUTIONS - CHARGER

- ATTENTION! THE UNIT IS SUPPLIED WITH HAZARDOUS MAINS VOLTAGE (230 V~). LEAVE SERVICING TO SKILLED PERSONNEL ONLY.
- UNQUALIFIED HANDLING MAY CAUSE AN ELECTRIC SHOCK HAZARD. IMPROPER OPENING OF THE DEVICE, OTHER TAMPERING OR CHANGES TO THE DEVICE WILL VOID THE WARRANTY.
- Use only recommended power sources.
- Only use the unit for recharging 12 V lead batteries.
- The unit is suitable for indoor use only. Protect it against any water contact, high air humidity and heat (admissible ambient temperature range 0 – 40 °C).
- Do not place any objects filled with liquid on the unit, e.g a glass.
- Do not allow dirt or metal objects (such as keys) to contact the charger terminals or plug. This could result in fire, electrical shock or other damage.
- The heat generated within the unit must be cooled. Therefore, never cover the housing.
- Unplug the battery charger from the power outlet after recharging is complete, or when you are not using it.

Do not operate the unit or immediately disconnect it from the mains socket:

1. if there is visible damage to the unit or the mains cable,
2. if a defect might have occurred after the unit was dropped or suffered a similar accident,
3. if malfunctions occur.

- In any case the unit must be repaired by skilled personnel.
- A damaged mains cable must be replaced by the manufacturer or authorized, skilled personnel only.
- Never pull the mains cable to disconnect the mains plug from the socket, always pull the plug.
- For cleaning only use a dry, soft cloth; never use chemicals or water.

• No guarantee claims for the unit and no liability for any resulting personal damage or material damage will be accepted if the unit is used for other purposes than originally intended, if it is not correctly connected, operated, or not repaired in an expert way.

Operation

- 1) Connect the mains plug of the charger to a mains socket. The LED is illuminated to indicate operation. The charging process has ended when the LED is lit green.
- 2) The charging time depends on the capacity and the charging status of the battery.